

# HM16123 SERVICEAREA DESK,BL.STONE/BL,ADJ,BASE

Office: 33F-03, Kaide Cloud Nine, No.6088 Humin Road, Minhang District, Shanghai, China  
 TEL: +86 37598021 FAX: +86 21 37598015  
 Factory: No. 168 Lanbo Road Fengxian District, Shanghai, China, 201411  
 TEL: +86 21 33688850 FAX: +86 21 37588103

**PROPRIETARY AND CONFIDENTIAL**

THE INFORMATION CONTAINED IN THIS DRAWING IS THE SOLE PROPERTY OF WINNER. ANY REPR ODUCTION IN PART OR AS A WHOLE WITHOUT THE WRITTEN PERMISS-ION OF WINNER IS PROHIBITED.

Project #:

**H&M**

Customer #:

**160485-01**

FINI: HES:

ST02: 白色喷粉

SN24: 灰色石头, 带碎纹

SS01: 拉丝不锈钢

ME01: 白色亚光

PL J7: 封边条

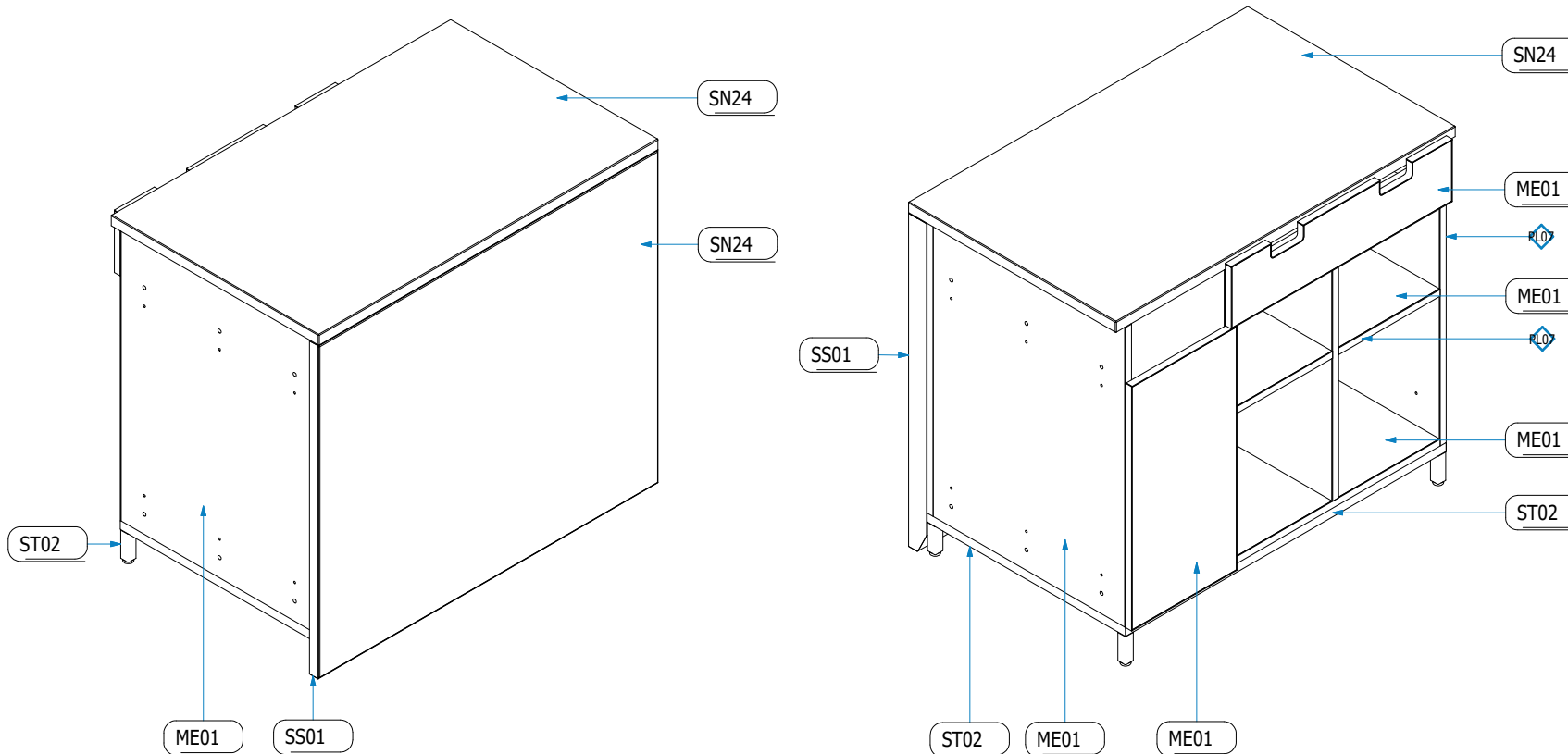

REV	DATE	DESCRIPTION
2	2015-05-25	1 改封口片尺寸及装配工艺

Part #: **HM16123**

Des: SERVICEAREA DESK,BL.STONE/BL,ADJ,BASE

Materials:

Qty:

Sheet No: 1 OF 41

Format: **A3** THE THIRD VIEW

Engineer: Zhujiabin

Check By:

DATE: 2015/9/11 REV 1

注明: 所有可见边均封边

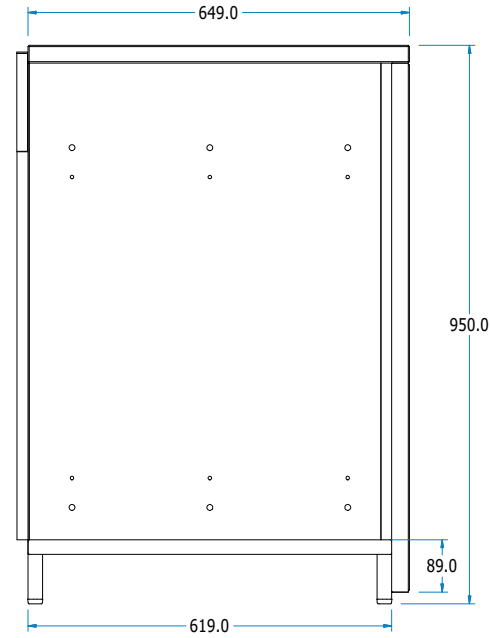
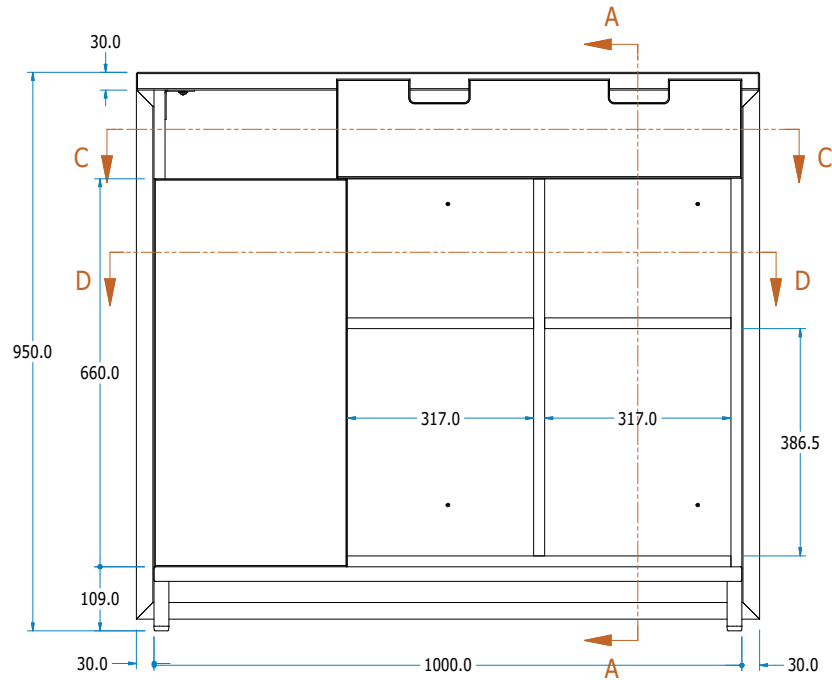
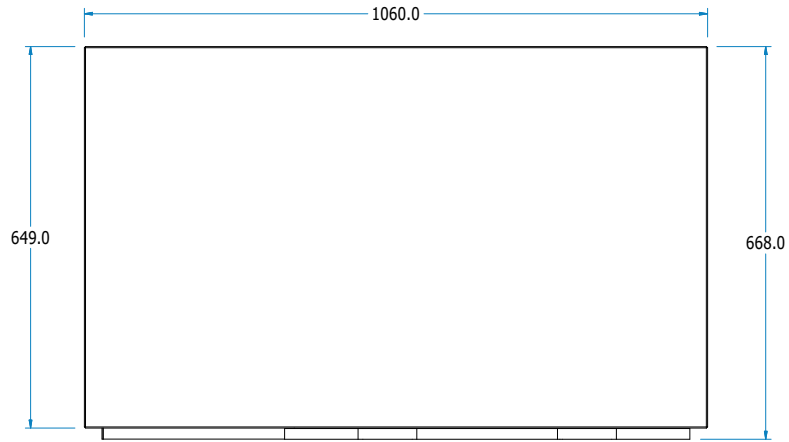

Office: 33F-03, Kaide Cloud Nine, No.6088 Humin Road, Minhang District, Shanghai, China  
 TEL: +86 37598021 FAX: +86 21 37598015  
 Factory: No. 168 Lanbo Road Fengxian District, Shanghai, China, 201411  
 TEL: +86 21 33688850 FAX: +86 21 37588103

**PROPRIETARY AND CONFIDENTIAL**

THE INFORMATION CONTAINED IN THIS DRAWING IS THE SOLE PROPERTY OF WINNER. ANY REPRODUCTION IN PART OR AS A WHOLE WITHOUT THE WRITTEN PERMISSION OF WINNER IS PROHIBITED.

Project #:

**H&M**

Customer #:

**160485-01**

FINISH: HES:

REV	DATE	DESCRIPTION

Part #: **HM16123**

Des: SERVICEAREA DESK,BL.STONE/BL,AD

Materials:

Qty:

Sheet No: 2 OF 41

Format: **A3** THE THIRD VIEW

Engineer: Zhujiabin

Check By:

DATE: 2015/9/11      REV    1

**PROPRIETARY AND CONFIDENTIAL**

THE INFORMATION CONTAINED IN THIS DRAWING IS THE SOLE PROPERTY OF WINNER. ANY REPRODUCTION IN PART OR AS A WHOLE WITHOUT THE WRITTEN PERMISSION OF WINNER IS PROHIBITED.

Project #:

**H&M**

Customer #:

**160485-01**

FINI: HES:

REV	DATE	DESCRIPTION

Part #: **HM16123**

Des: **SERVICEAREA DESK,BL.STONE/BL,AD**

Materials:

Qty:

Sheet No: **3 OF 41**

Format: **A3** THE THIRD VIEW

Engineer: **Zhujiabin**

Check By:

DATE: **2015/9/11**

REV **1**

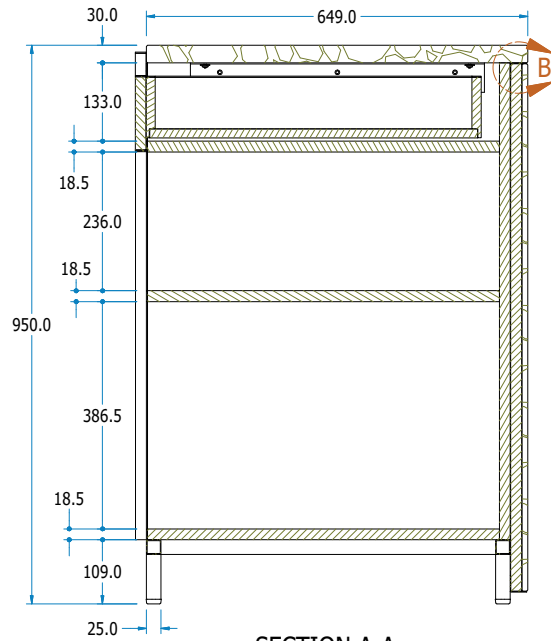

**SECTION A-A**  
SCALE 0.11 : 1

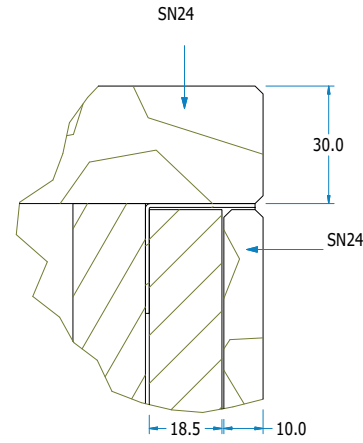

**DETAIL B**  
SCALE 0.22 : 0.3

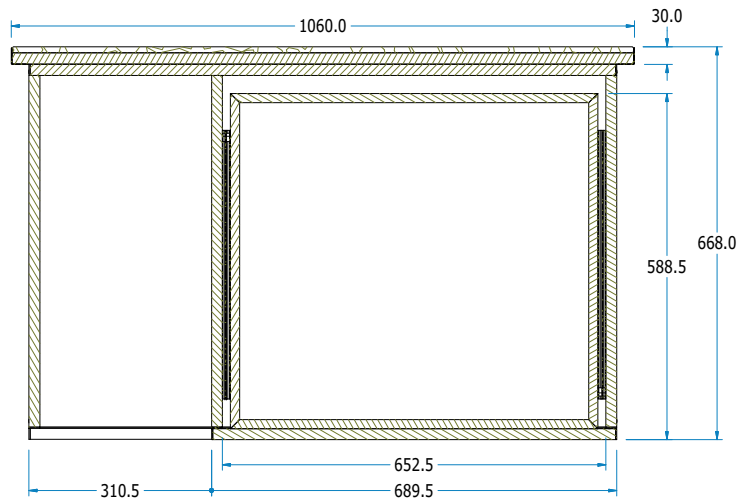

**SECTION C-C**  
SCALE 0.11 : 1

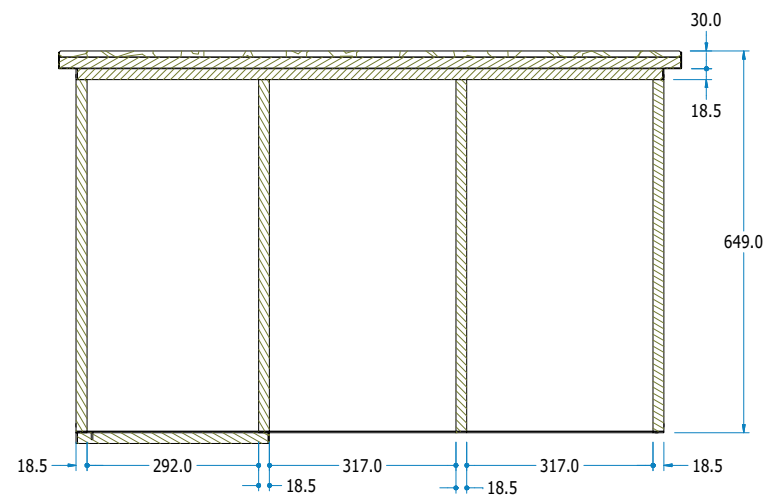

**SECTION D-D**  
SCALE 0.11 : 1

**BILL OF MATERIALS**

QTY	PART#	DESCRIPTION	MATERIAL	THK	WID	LEN	T_LEN	库存编号
1	HM16123-01	框架						
1	HM16123-02	抽屉						
1	HM16123-03	大理石面板						
1	HM16123-04	翻板(大理石)						
3	HM16123-05	L型连接件	A冷轧钢	2.0 mm	97.5 mm	500.0 mm		
1	HM16123-06	底座						

Office: 33F-03, Kaide Cloud Nine, No.6088 Humin Road, Minhang District, Shanghai, China  
 TEL: +86 37598021 FAX: +86 21 37598015  
 Factory: No. 166 Lanbo Road Fengxian District, Shanghai, China 201411  
 TEL: +86 21 33688850 FAX: +86 21 37588103

**PROPRIETARY AND CONFIDENTIAL**

THE INFORMATION CONTAINED IN THIS DRAWING IS THE SOLE PROPERTY OF WINNER. ANY REPRODUCTION IN PART OR AS A WHOLE WITHOUT THE WRITTEN PERMISSION OF WINNER IS PROHIBITED.

Project #:

**H&M**

Customer #:

**160485-01**

FINN HES:

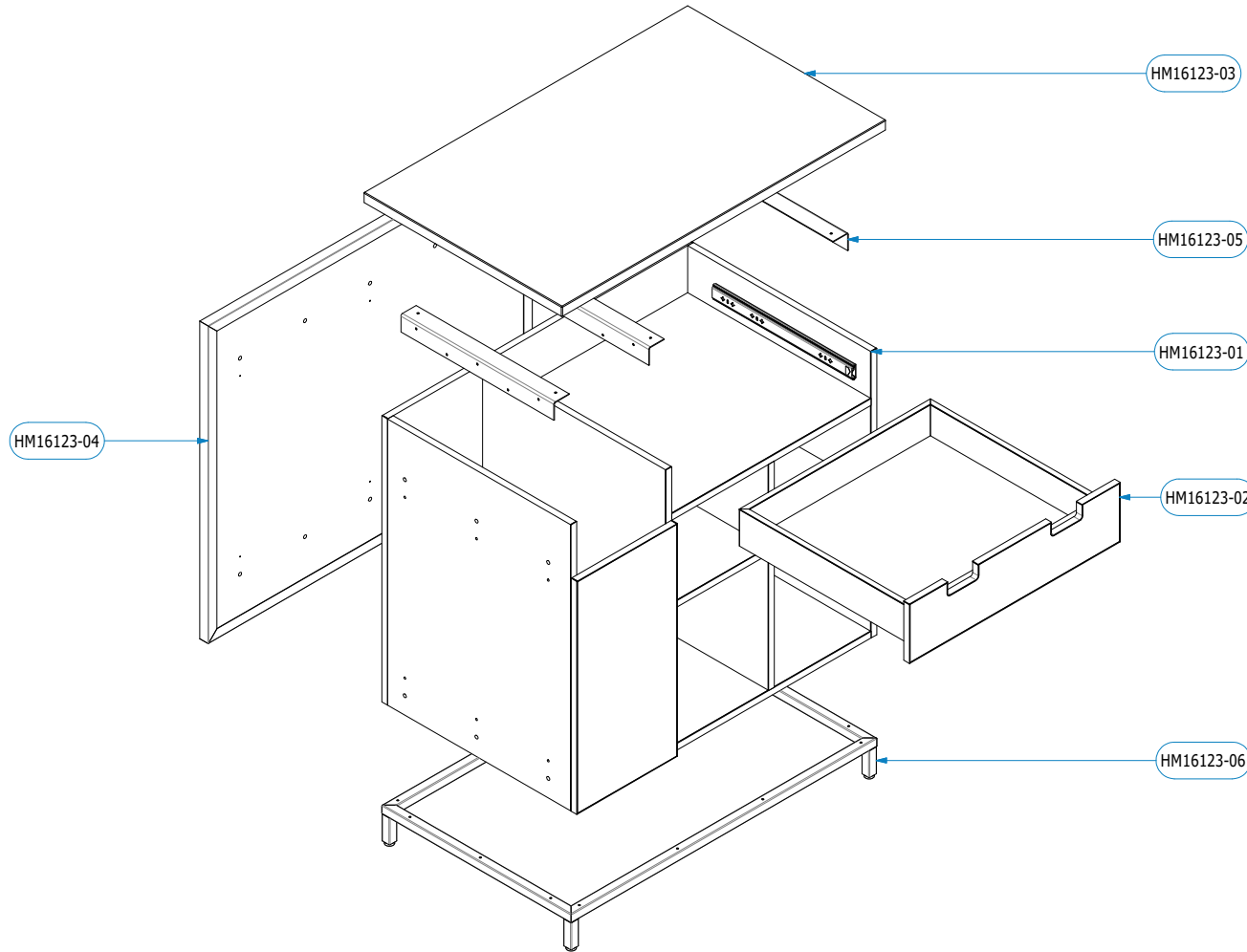

REV	DATE	DESCRIPTION

Part #: **HM16123**

Des: **SERVICEAREA DESK,BL.STONE/BL,AD**

Materials:

Qty:

Sheet No: **4 OF 41**

Format: **A3** THE THIRD VIEW

Engineer: **Zhujiabin**

Check By:

DATE: **2015/9/11** REV **1**



Office: 33F-03, Kaide Cloud Nine, No.6088 Humin Road, Minhang District, Shanghai, China  
 TEL: +86 37598021 FAX: +86 21 37598015  
 Factory: No. 166 Lanbo Road Fengxian District, Shanghai, China 201411  
 TEL: +86 21 33688850 FAX: +86 21 37588103

**PROPRIETARY AND CONFIDENTIAL**

THE INFORMATION CONTAINED IN THIS DRAWING IS THE SOLE PROPERTY OF WINNER. ANY REPRODUCTION IN PART OR AS A WHOLE WITHOUT THE WRITTEN PERMISSION OF WINNER IS PROHIBITED.

Project #:

**H&M**

Customer #:

**160485-01**

**FINISHES:**

REV	DATE:	DESCRIPTION

Part #: **HM16123-01**

Des: 框架

Materials:

Qty:

Sheet No: 6 OF 41

Format: **A3** THE THIRD VIEW

Engineer: Zhujiabin

Check By:

DATE: 2015/9/11

REV 1

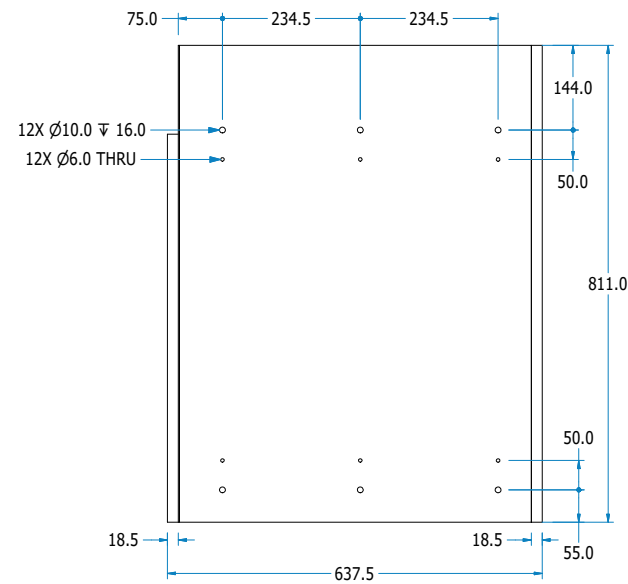
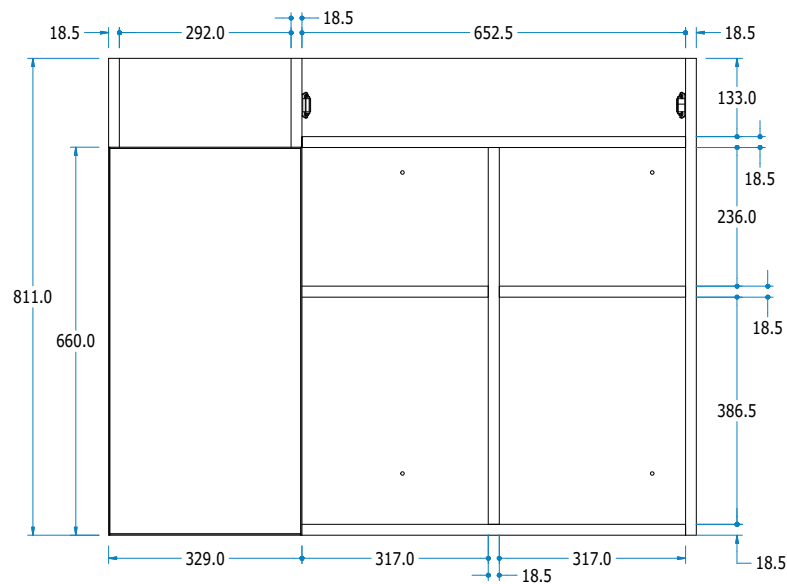
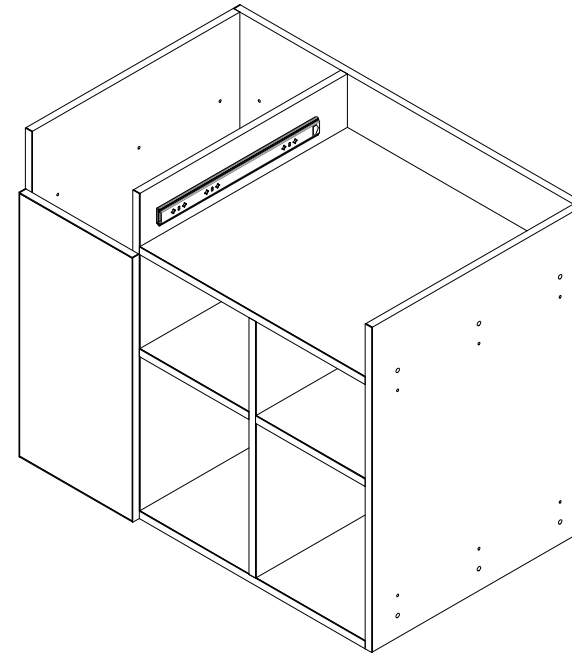
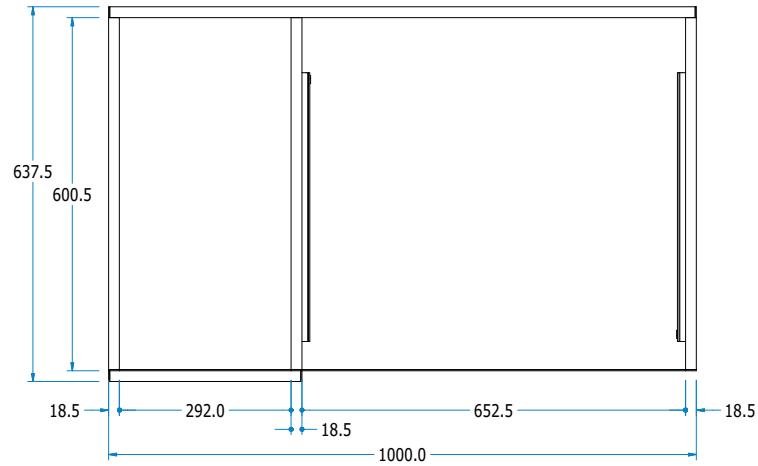

**BILL OF MATERIALS**

QTY	PART#	DESCRIPTION	MATERIAL	THK	WID	LEN	T_LEN	库存编号
2	450mm三节导轨 (阻尼)	450mm加重三节轨道 白色	A镀锌板					
1	HM16123-01-01-01	底板	A双贴白色三聚氰胺板	18.5 mm	598.5 mm	963.0 mm		
0.9630 m	HM16123-01-01-02		A塑料ABS	2.0 mm	18.5 mm	963.0 mm		
1	HM16123-01-02-01	左侧板	A双贴白色三聚氰胺板	18.5 mm	598.5 mm	811.0 mm		
0.8110 m	HM16123-01-02-02		A塑料ABS	2.0 mm	18.5 mm	811.0 mm		
1	HM16123-01-03-01	背板	A双贴白色三聚氰胺板	18.5 mm	811.0 mm	996.0 mm		
2.4330 m	HM16123-01-03-02		A塑料ABS	2.0 mm	18.5 mm	811.0 mm		
1	HM16123-01-04-01	右侧板	A双贴白色三聚氰胺板	18.5 mm	598.5 mm	811.0 mm		
1	HM16123-01-05-01	隔板 (小)	A双贴白色三聚氰胺板	18.5 mm	598.5 mm	641.0 mm		
0.6410 m	HM16123-01-05-02		A塑料ABS	2.0 mm	18.5 mm	641.0 mm		
1	HM16123-01-06-01	中侧板	A双贴白色三聚氰胺板	18.5 mm	598.5 mm	792.5 mm		
0.7925 m	HM16123-01-06-02		A塑料ABS	2.0 mm	18.5 mm	792.5 mm		
2	HM16123-01-07-01	层板 (小)	A双贴白色三聚氰胺板	18.5 mm	598.5 mm	317.0 mm		
0.6340 m	HM16123-01-07-02		A塑料ABS	2.0 mm	18.5 mm	317.0 mm		
1	HM16123-01-08-01	层板	A双贴白色三聚氰胺板	18.5 mm	598.5 mm	652.5 mm		
0.6525 m	HM16123-01-08-02		A塑料ABS	2.0 mm	18.5 mm	652.5 mm		
1	HM16123-01-09-01	门板	A双贴白色三聚氰胺板	18.5 mm	325.0 mm	656.0 mm		
0.6500 m	HM16123-01-09-02		A塑料ABS	2.0 mm	18.5 mm	325.0 mm		
1.3200 m	HM16123-01-09-03		A塑料ABS	2.0 mm	18.5 mm	660.0 mm		

**BILL OF MATERIALS**

QTY	PART#	DESCRIPTION	MATERIAL	THK	WID	LEN	T_LEN	库存编号
2	450mm三节导轨 (阻尼)	450mm加重三节轨道 白色	A镀锌板					
1	HM16123-01-01	底板						
1	HM16123-01-02	左侧板						
1	HM16123-01-03	背板						
1	HM16123-01-04	右侧板						
1	HM16123-01-05	隔板 (小)						
1	HM16123-01-06	中侧板						
2	HM16123-01-07	层板 (小)						
1	HM16123-01-08	层板						
1	HM16123-01-09	门板						

Office: 33F-03, Kaide Cloud Nine, No.6088 Humin Road, Minhang District, Shanghai, China  
 TEL: +86 37598021 FAX: +86 21 37598015  
 Factory: No. 168 Lanbo Road Fengxian District, Shanghai, China, 201411  
 TEL: +86 21 33688850 FAX: +86 21 37588103

**PROPRIETARY AND CONFIDENTIAL**

THE INFORMATION CONTAINED IN THIS DRAWING IS THE SOLE PROPERTY OF WINNER. ANY REPR ODUCTION IN PART OR AS A WHOLE WITHOUT THE WRITTEN PERMISS ION OF WINNER IS PROHIBITED.

Project #:

**H&M**

Customer #:

**160485-01**

**FINISHES:**

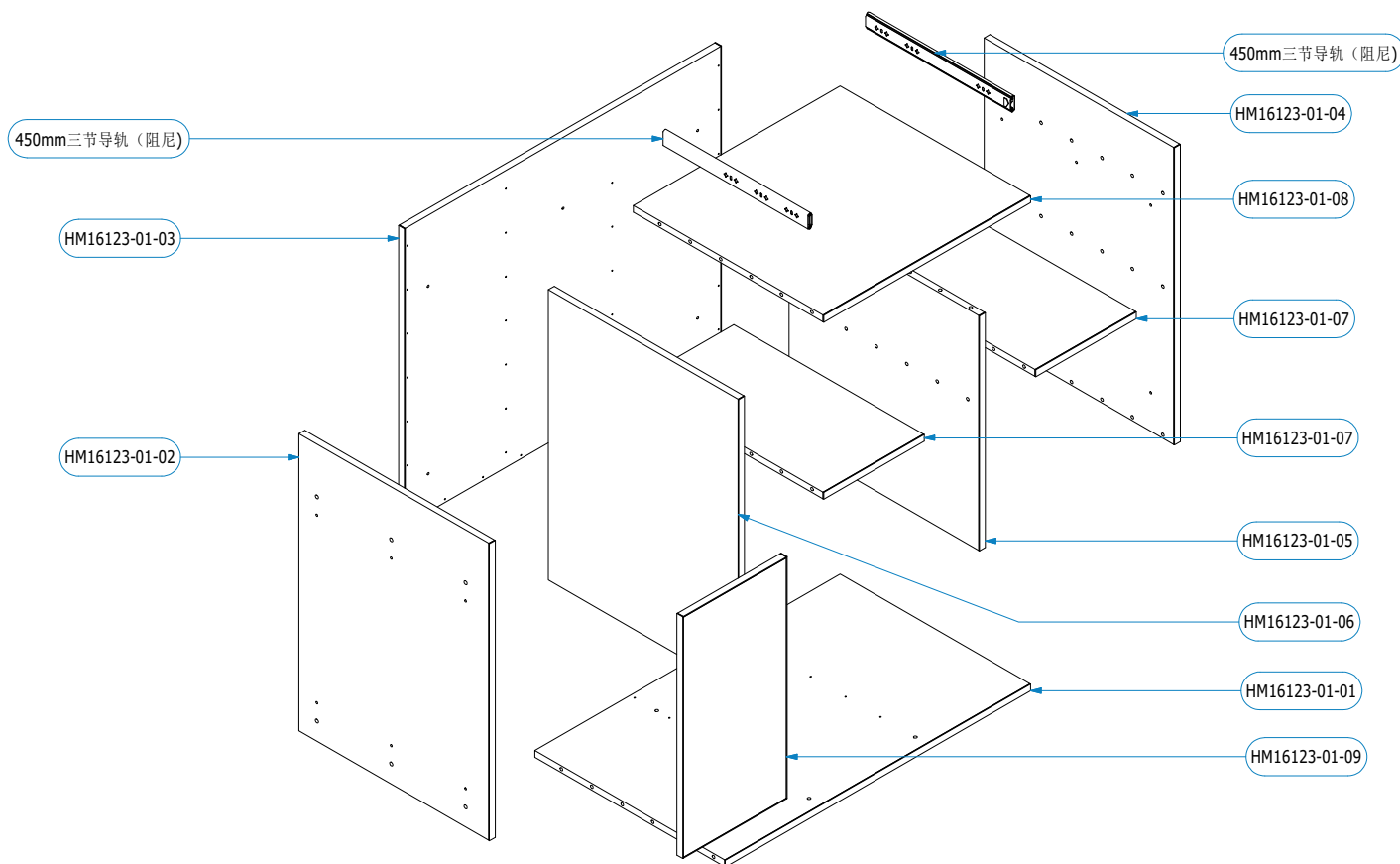

REV	DATE:	DESCRIPTION

Part #: **HM16123-01**

Des: 框架

Materials:

Qty:

Sheet No: 7 OF 41

Format: **A3** THE THIRD VIEW

Engineer: Zhujiabin

Check By:

DATE: 2015/9/11 REV 1

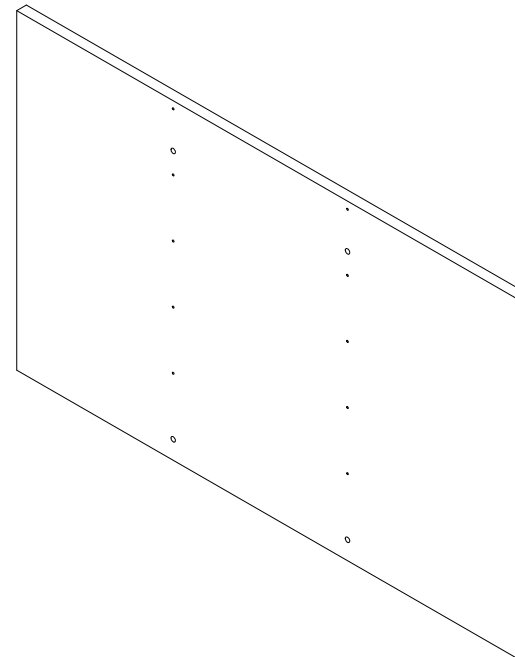
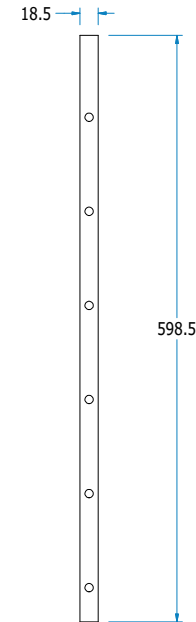
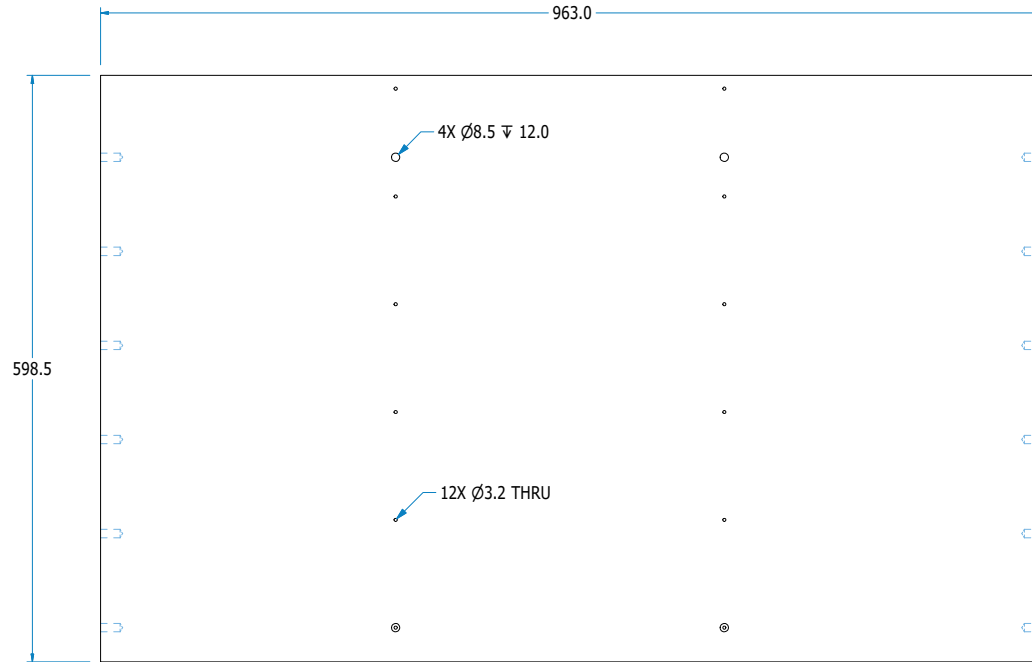

Office: 33F-03, Kaide Cloud Nine, No.6088 Humin Road, Minhang District, Shanghai, China  
 TEL: +86 37598021 FAX: +86 21 37598015  
 Factory: No. 168 Lanbo Road Fengxian District, Shanghai, China 201411  
 TEL: +86 21 33688850 FAX: +86 21 37588103

**PROPRIETARY AND CONFIDENTIAL**

THE INFORMATION CONTAINED IN THIS DRAWING IS THE SOLE PROPERTY OF WINNER. ANY REPRODUCTION IN PART OR AS A WHOLE WITHOUT THE WRITTEN PERMISSION OF WINNER IS PROHIBITED.

Project #:

**H&M**

Customer #:

**160485-01**

**FINISHES:**

REV	DATE:	DESCRIPTION

Part #: **HM16123-01-01-01**

Des: 底板

Materials: A双贴白色三聚氰胺板

Qty:

Sheet No: 8 OF 41

Format: **A3** THE THIRD VIEW

Engineer: Zhujiabin

Check By:

DATE: 2015/9/11	REV	1
-----------------	-----	---



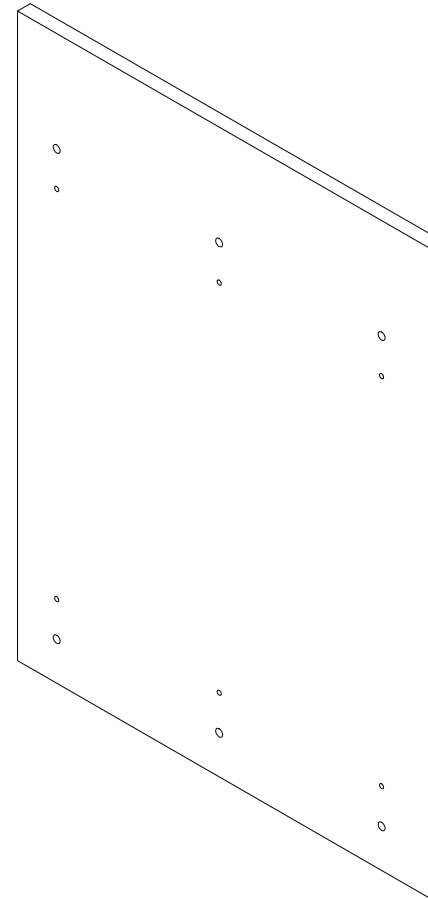
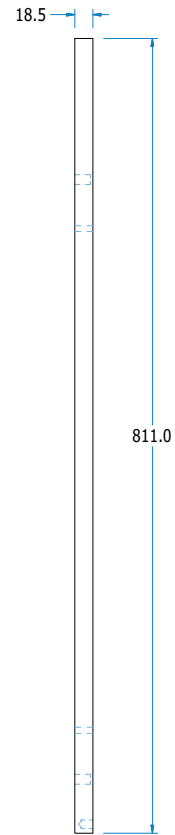
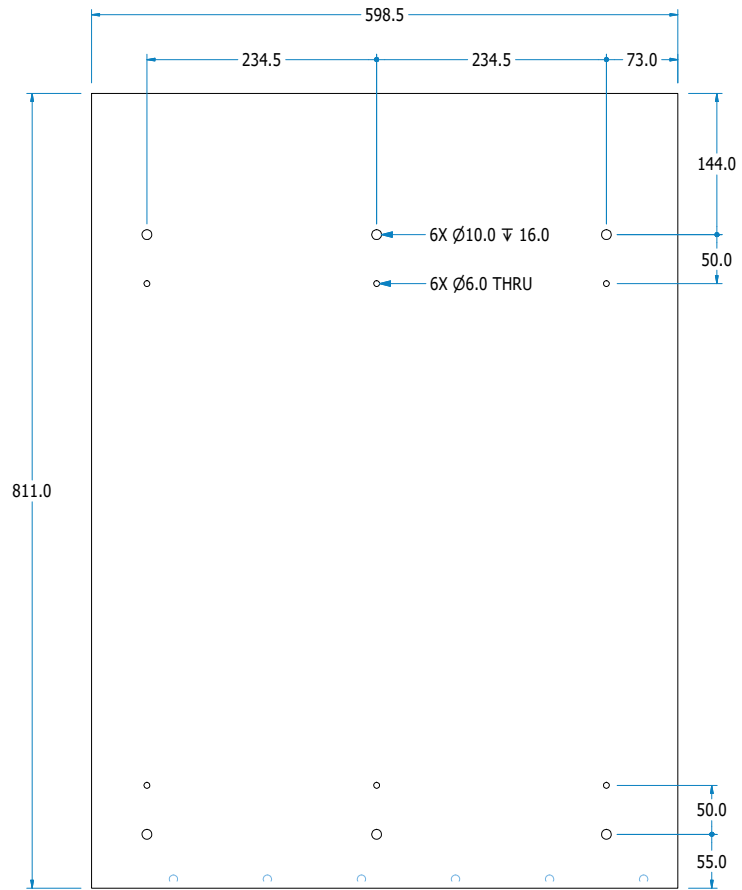

Office: 33F-03, Kaide Cloud Nine, No.6088 Humin Road, Minhang District, Shanghai, China  
 TEL: +86 37598021 FAX: +86 21 37598015  
 Factory: No. 168 Lanbo Road Fengxian District, Shanghai, China 201411  
 TEL: +86 21 33688850 FAX: +86 21 37588103

**PROPRIETARY AND CONFIDENTIAL**

THE INFORMATION CONTAINED IN THIS DRAWING IS THE SOLE PROPERTY OF WINNER. ANY REPRODUCTION IN PART OR AS A WHOLE WITHOUT THE WRITTEN PERMISSION OF WINNER IS PROHIBITED.

Project #:

**H&M**

Customer #:

**160485-01**

**FINISHES:**

REV	DATE:	DESCRIPTION

Part #: **HM16123-01-02-01**

Des: 左侧板

Materials: A双贴白色三聚氰胺板

Qty:

Sheet No: 9 OF 41

Format: **A3** THE THIRD VIEW

Engineer: Zhujiabin

Check By:

DATE: 2015/9/11 REV 1

Office: 33F-03, Kaide Cloud Nine, No.6088 Humin Road, Minhang District, Shanghai, China  
 TEL: +86 37598021 FAX: +86 21 37598015  
 Factory: No. 168 Lanbo Road Fengxian District, Shanghai, China 201411  
 TEL: +86 21 33688850 FAX: +86 21 37588103

**PROPRIETARY AND CONFIDENTIAL**

THE INFORMATION CONTAINED IN THIS DRAWING IS THE SOLE PROPERTY OF WINNER. ANY REPRODUCTION IN PART OR AS A WHOLE WITHOUT THE WRITTEN PERMISSION OF WINNER IS PROHIBITED.

Project #:

**H&M**

Customer #:

**160485-01**

**FINISHES:**

REV	DATE:	DESCRIPTION

Part #: **HM16123-01-03-01**

Des: 背板

Materials: A双贴白色三聚氰胺板

Qty:

Sheet No: 10 OF 41

Format: **A3** THE THIRD VIEW 

Engineer: Zhujiabin

Check By:

DATE: 2015/9/11 REV 1

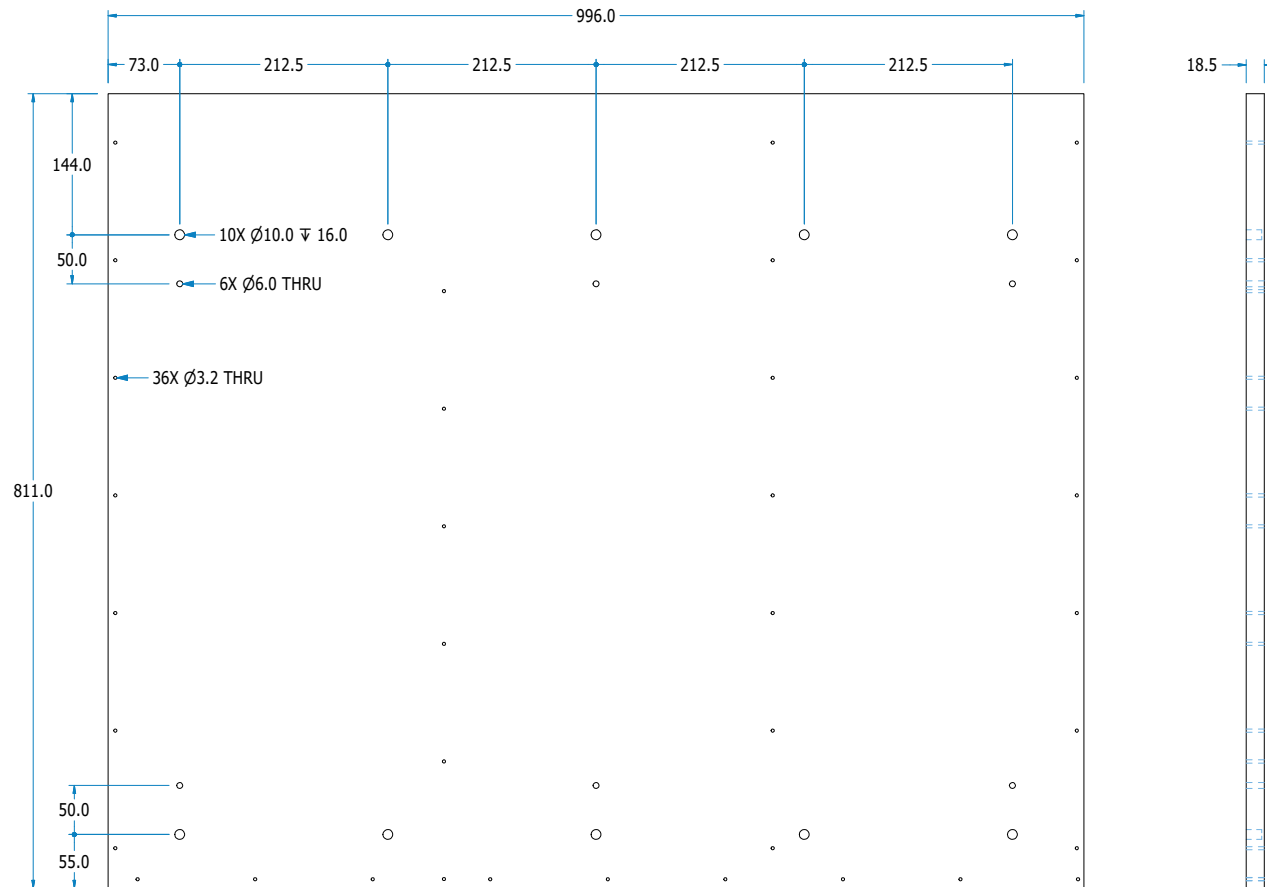

以上内容仅为本文档的试下载部分，为可阅读页数的一半内容。如要下载或阅读全文，请访问：<https://d.book118.com/398064012007006120>