

 **NETCOM<sup>®</sup> MODEL ADH**  
AUTOMATIC AIR DEHYDRATOR WITH ETHERNET

**TABLE OF CONTENTS**

Safety Information and Warnings..... 2  
Unpacking the Unit..... 3  
Inventory..... 4  
Glossary ..... 5  
Product Features..... 6  
Mean Time Between Failure Statement..... 8  
Description and Theory of Operation ..... 9  
Machine Preparation and Set-Up ..... 12  
Installation ..... 14  
Computer Network Communications ..... 21  
Configuring the System - User Inputs..... 22  
Alarms ..... 29  
Configuring the Alarm Relays..... 30  
Operation ..... 31  
Maintenance..... 32  
Troubleshooting ..... 33  
Replacement Parts..... 48  
Specifications ..... 49  
Appendix A - The ADH NETCOM AC NEMA Configuration ..... 51  
Appendix B - Communications Protocols ..... 58  
Appendix C - Master Configuration..... 63  
Appendix D - Optional Front Panel..... 64  
Ordering Information..... 70

## SAFETY INFORMATION AND WARNINGS



### Abnormal Odor or Smoke

In the event of smoke or a burning or abnormal odor, immediately interrupt power to the ADH NETCOM with the POWER switch at the rear of the unit, unplug the unit, or turn off the circuit breaker controlling the outlet. Note that only the AC model of the ADH NETCOM has an ON / OFF switch.

### Odeur ou fumée anormale

En cas de fumée ou de brûlure ou d'odeur anormale, coupez immédiatement l'alimentation de l'ADH NETCOM avec l'interrupteur POWER à l'arrière de l'appareil, débranchez l'appareil ou éteignez le disjoncteur contrôlant la prise. Notez que seul le modèle AC de l'ADH NETCOM a un interrupteur ON / OFF.



### Lethal Voltages Present

Lethal voltages are present inside the ADH NETCOM. Service should be performed by qualified personnel only. There are no user serviceable components inside the chassis.

### Tensions létales présentes

Des tensions mortelles sont présentes à l'intérieur du ADH NETCOM. L'entretien doit être effectué uniquement par du personnel qualifié. Il n'y a aucun composant réparable par l'utilisateur à l'intérieur du châssis.



### Pneumatics

Each of the air pumps inside the ADH NETCOM automatic air dehydrator is capable of generating as much as 24 psig (1,655mbar). Other attached dry air sources may be capable of generating even higher pressures. Proper safety practice requires treating all pneumatic components with care. Always vent the system to atmospheric pressure before servicing pneumatic components.

### Pneumatique

Chacune des pompes à air à l'intérieur du déshydrateur d'air automatique ADH NETCOM peut générer jusqu'à 24 psig (1 655 mbar). D'autres sources d'air sec fixées peuvent être capables de générer des pressions encore plus élevées. Une bonne pratique de sécurité nécessite de traiter tous les composants pneumatiques avec soin. Purgez toujours le système à la pression atmosphérique avant de procéder à l'entretien des composants pneumatiques.



### Rack Mounting

Before and after rack mounting the ADH NETCOM, ensure that the rack is stable. Mounting of the ADH NETCOM into a rack should be such that a hazardous condition is not created due to uneven mechanical loading. Verify that adequate air flow and power source capacity is available to the unit. Ensure that the ADH NETCOM maximum operating temperature of 130°F (55°C) will not be compromised by other components in the rack. Ensure reliable earthing of the ADH NETCOM.

### Montage en rack

Avant et après le montage en rack de l'ADH NETCOM, assurez-vous que le rack est stable. Le montage de l'ADH NETCOM dans un rack doit être tel qu'aucune condition dangereuse ne soit créée en raison d'une charge mécanique inégale. Vérifiez que le débit d'air et la capacité de la source d'alimentation sont disponibles pour l'unité. Assurez-vous que la température de fonctionnement maximale ADH NETCOM de 131 ° F (55 ° C) ne sera pas compromise par d'autres composants du rack. Assurer une mise à la terre fiable de l'ADH NETCOM.

## UNPACKING THE UNIT

Immediately upon receipt, inspect the container and packing material for any noticeable damage. Unpack the ADH NETCOM, taking care not to damage the packing materials. Save the shipping container and related materials until normal operation has been established. If the unit must be returned, take care to ensure that it is repackaged as it was received.

As soon as it arrives at your facility, inspect the ADH NETCOM for electrical and mechanical damage. If any of the following problems are found, contact Environmental Technology, Inc., Customer Service immediately:

- contents incomplete or incorrect;
- internal or external mechanical damage; or
- defective operation.

Environmental Technology, Inc., Customer Service is available between 8:00 a.m. and 5:00 p.m. Eastern Time. In the event of shipping damage, keep the packing materials for inspection by the carrier.

## RETURNS AND REPLACEMENT PART PURCHASES

Prior to removal of equipment for return, please contact Environmental Technology, Inc., Technical Support for troubleshooting assistance.

Before returning an ADH NETCOM to Environmental Technology, Inc., obtain a Return Merchandise Authorization from our Customer Service Department, available between 8:00 a.m. and 5:00 p.m. Eastern Time. If possible, use the original container and packing materials when packing the ADH NETCOM for shipment. It is important to mark the Return Merchandise Authorization clearly on the outside of the shipping container so that it may be correctly processed upon receipt at Environmental Technology.

For more information about replacement parts or for a replacement Data Sheet or Manual, please visit [www.networketi.com](http://www.networketi.com).

## INVENTORY

Using the information below, verify that the shipping package contains all of the parts listed. If there are any discrepancies, notify Environmental Technology, Inc., Customer Service immediately. Customer Service is available between 8:00 a.m. and 5:00 p.m. Eastern Time.

QTY.	PART NO.	DESCRIPTION	TABLE 1. Packing List for ADH NETCOM, AC MODEL.
1	25526	ADH NETCOM Automatic Air Dehydrator AC Power Supply	
1	25546	ADH NETCOM AC Installation Sheet	
1	17618	Power Cord, Euro	
1	18198	1/8" NPT to 1/4" Barbed Brass Fitting	
1	23428	1/8" NPT to 3/8" Barbed Brass Fitting	
1	14513	1/8" NPT to 1/4" Barbed Elbow Brass Fitting	
4	23245	Mounting Bracket	
8	24567	Self-Locking Rack-Mounting Screw (#8-32)	
8	10641	#8 Split Washer	

QTY.	PART NO.	DESCRIPTION	TABLE 2. Packing List for ADH NETCOM, DC MODEL.
1	25527	ADH NETCOM Automatic Air Dehydrator DC Redundant Power Supply	
1	23229	ADH NETCOM Installation Sheet	
1	18198	1/8" NPT to 1/4" Barbed Brass Fitting	
1	23428	1/8" NPT to 3/8" Barbed Brass Fitting	
1	14513	1/8" NPT to 1/4" Barbed Elbow Brass Fitting	
4	23245	Mounting Bracket	
8	24567	Self-Locking Rack-Mounting Screw (#8-32)	
8	10641	#8 Split Washer	

TABLE 3. Packing List for ADH NETCOM NEMA, AC MODEL.

QTY.	PART NO.	DESCRIPTION
1	25523	ADH NETCOM Automatic Air Dehydrator, NEMA AC Power Supply
1	25547	ADH NETCOM NEMA, AC Installation Sheet
1	18198	1/8" NPT to 1/4" Barbed Brass Fitting
1	23428	1/8" NPT to 3/8" Barbed Brass Fitting
1	23571	Bronze Exhaust Muffler (for use as moisture diffuser)

## GLOSSARY

### DUTY CYCLE

The amount of time, expressed as a percentage, that the unit is actually on, cycling, and pumping pressurized dry air.

### HIGH DUTY CYCLE ALARM LEVEL

The configurable set point at which the ADH NETCOM will indicate a high duty cycle. The factory default setting is 50%. The system duty cycle and the discharge pressure are available for display. Typically, the system should be tight enough to limit the duty cycle to less than 20%. System component life decreases as duty cycle increases. A Duty Cycle Alarm occurs if the duty cycle exceeds the configured Duty Cycle Alarm level.

### HIGH LIMIT TARGET PRESSURE

The high set point of the operating pressure range for the dehydrator. This is the pressure setting which the unit will target during compressor operation. The actual turn-off pressure is adjusted in the software every pressurization cycle after determining the rate of pressure change during that cycle. This software compensation for the rate of pressure change during pressurization minimizes compressor "undershoot." The High Limit Target Pressure must be between 0.20 psig and 7.5 psig (14mbar to 517mbar). The factory default setting for High Limit Target Pressure is 0.5 psig (34.5mbar).

### HIGH PRESSURE ALARM LEVEL

The user-configurable high pressure limit at which an alarm condition will be indicated. Note that the High Pressure Alarm Level must be set higher than the High Limit Target Pressure setting. The factory default setting is 1.5 psig (103.5mbar). A High Pressure Alarm occurs if the pressure exceeds the configured High Pressure Alarm Level for more than 30 seconds. Mechanical Overpressure protection is recommended within the system to prevent pressure reaching the High Pressure Alarm level.

### LOW LIMIT TARGET PRESSURE

The low set point of the operating pressure range for the dehydrator. This is the pressure setting at which the unit will turn off the compressor during compressor operation. The Low Limit Target Pressure must be set lower than the High Limit Target Pressure by at least 0.1 psig (7mbar). The factory default Low Limit Target Pressure is 0.30 psig (21mbar).

### LOW PRESSURE ALARM LEVEL

The user-configurable low pressure limit at which an alarm condition will be indicated. Note that the Low Pressure Alarm Level setting must be set lower than the Low Limit Target Pressure setting, and that the factory default setting

is 0.15 psig (10mbar). A Low Pressure Alarm occurs if the pressure stays below the configured Low Pressure Alarm Level for more than 30 seconds.

### **SOLAR GAIN**

Generally occurring each day at sunrise, the time when sunlight and heat increase, resulting in a natural corresponding rise in temperature and pressure inside a cable line. Solar gain can also occur before or after a major weather effect.

### **VSWR**

VSWR means Voltage Standing Wave Ratio and is used to measure the amount of energy that is reflected back into the transmitter from the antenna when the antenna is not tuned properly. Water in the transmission line will de-tune the antenna and cause a higher VSWR.

## **PRODUCT FEATURES**

Major features of the ADH NETCOM automatic air dehydrator are listed below. Refer to Figures 1 and 2 for schematic drawings of the ADH NETCOM AC and DC unit configurations.

The ADH NETCOM is functionally equivalent to the earlier ADH-2ACOM and the ADH-3COM automatic air dehydrators with regards to basic mechanical features such as air drying and pressurization. The ADH NETCOM automatic

air dehydrator offers improved network communications, extended product life expectancy, and simplified ordering and installation. Product features include:

- A drop-in replacement for previous ADH models currently in service
- Similar specifications to earlier ADH models
- Indoor and outdoor mounting options
- 100 to 240 VAC and +/- 20 to 75 VDC power options
- All operational parameters can be easily set by simple web interface
- Communications interfaces include Ethernet networking, RS-422/485, and RS-232
- Network communication protocols include HTTP, SNMP, UDP, and Scientific-Atlanta (S-A)
- Master/slave functionality for automatic operations of paralleled dehydrators
- Interface for the ASM-1 Smart Manifold for automatic operation of one or more antennas from one or more dehydrators
- Complete set of programmable alarms, including three user-configurable alarm relays
- Software can be updated remotely through the network interface, permitting performance updates throughout the life of the dehydrator

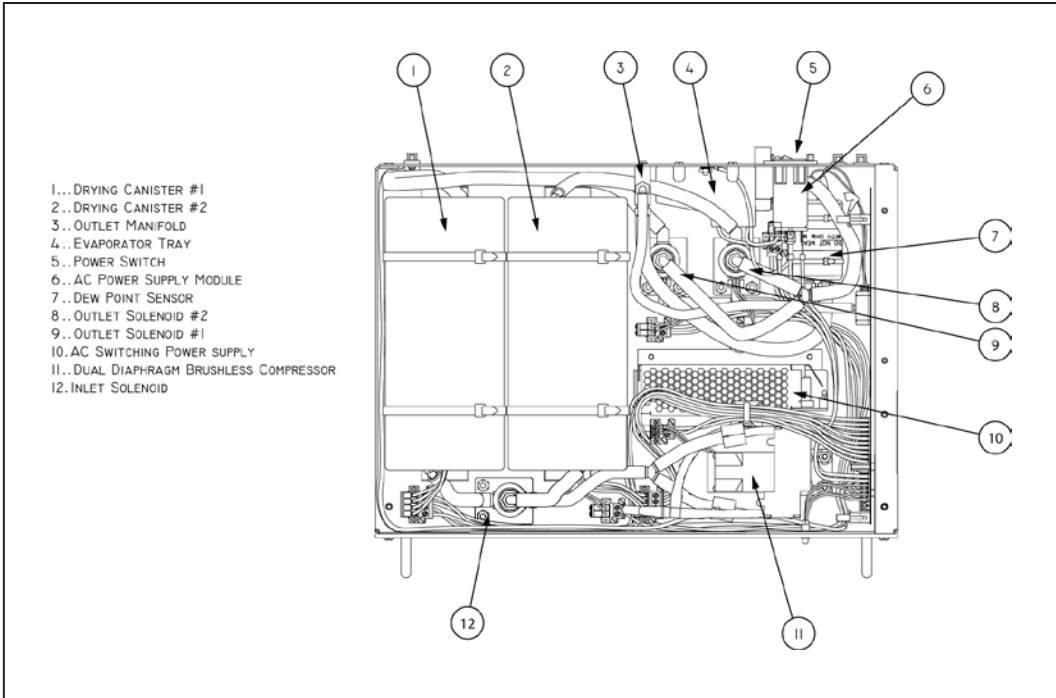

FIGURE 1. ADH NETCOM AC Unit Components.

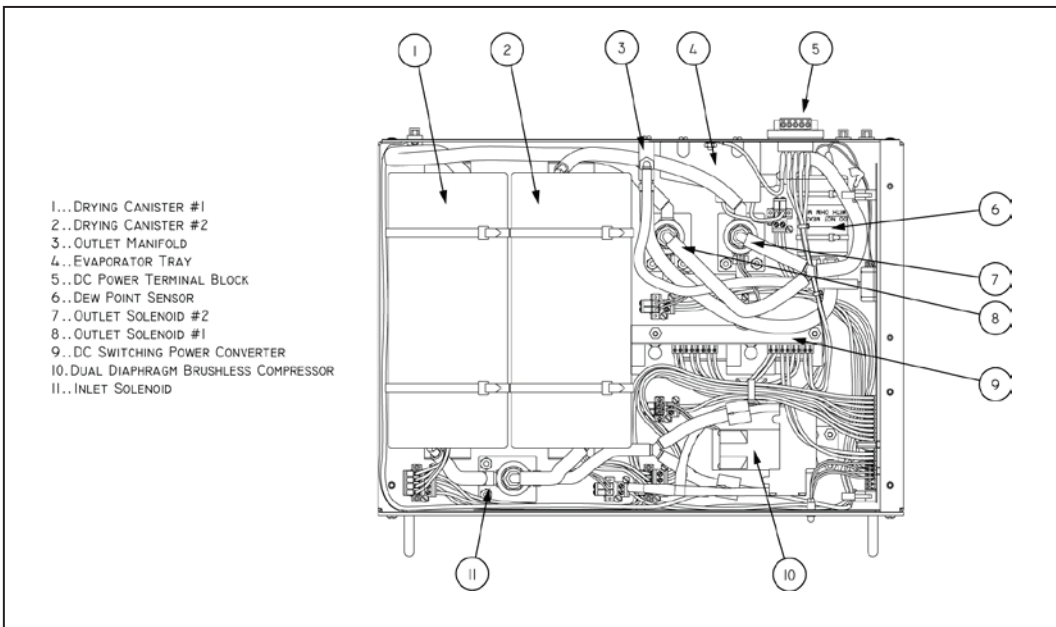

FIGURE 1. ADH NETCOM DC Unit Components.

## ADH NETCOM AUTOMATIC AIR DEHYDRATOR MEAN TIME BETWEEN FAILURE RELIABILITY STATEMENT

Environmental Technology, Inc., hereby confirms that all original components and spare or replacement parts used in the ADH NETCOM Automatic Air Dehydrator have the reliability characteristics stated below. The ADH NETCOM meets or exceeds our previous generation of automatic air dehydrators in all aspects of fit, form, and function.

ADH NETCOM - Overall Reliability Mean Time Between Failure (MTBF) Rate: More than 75,000 hours when maintaining a 5% or lower duty cycle.

### ADH NETCOM AUTOMATIC AIR DEHYDRATOR ORIGINAL COMPONENT AND REPLACEMENT PART RELIABILITY LIST

PART DESCRIPTION	COMPONENT PART NUMBER	REPLACEMENT KIT PART NUMBER	MTBF (HOURS)	STORAGE (°C)
Main Circuit Board	23253	24084	75,000+	-40 to +60
Compressor Assembly	23216	24085	160,000+	-40 to +60
Absorption Unit (Air Drying Canister)	23218	24054	96,000+	-40 to +60
Power Filter Module and Switch (AC)	23446	24086	458,900+	-40 to +60
Power Filter Module (NEMA)	23563	24087	458,900+	-40 to +60
Discharge Manifold with safety relief valve	23173	24088	100,000+	-40 to +60
Solenoid, Outlet	23214	24090	150,000+	-40 to +60
Solenoid, Inlet	23270	24096	150,000+	-40 to +60
Humidity Sensor Assembly	23368	24091	75,000+	-40 to +60
Humidity Sensor Assembly (NEMA)	23707	24092	75,000+	-40 to +60
ADH NETCOM Manual	23526	(23526)	-	-
AC Power Supply Module	23450	24094	420,500+	-40 to +60
AC Power Supply Module (NEMA)	23566	24093	420,500+	-40 to +60
DC Dual Redundant Power Supply Module	23224	24095	100,000+	-40 to +60



## DESCRIPTION AND THEORY OF OPERATION

A detailed product description and theory of operation for the ADH NETCOM automatic air dehydrator are presented below.

### FUNCTION

Unpressurized transmission lines allow the entry of moist ambient air through leaking seals and cracks. When the line passes from one environment to another (such as entering a shelter from the antenna outside) or when there is a change in existing environmental conditions (such as a weather front or nightfall) the pressure and/or temperature changes in the air will result in the collection of water inside the line. This is normally the result of the ambient temperature dropping below the dew point. Water in transmission lines causes corrosion, voltage arcing, and increased VSWR, all of which reduce system performance.

The ADH NETCOM automatic air dehydrator prevents the accumulation of moisture in transmission lines by maintaining the pressure and dew point of the air inside the line. Supplying low pressure dry air, the ADH NETCOM keeps waveguides, air-dielectric coaxial cable and related components used in earth station and terrestrial UHF and microwave communication systems dry.

### PRINCIPAL CONSIDERATIONS

The ADH NETCOM works best supplying dry air in a flowing system, where the dehydrator completely replaces the air on a regular basis. Consequently, the equipment being supplied dry air should have a bleed system. For a waveguide, this is best accomplished by slightly opening a purge valve at the window end of the system. Installing a pressure relief valve, purposely set higher than the High Limit Target Pressure, will allow the solar pressure gain to bleed off. This will provide for greater system stability and repetitive daily performance and results. Likewise, air dielectric coaxial cable should be equipped with a valve at the far end which can be set to allow a small continuous bleed. Many systems will have sufficient normal leakage

that such actions might not be necessary. For optimal performance and life expectancy of the dehydrator a duty cycle between 1% and 10% is recommended.

The ADH NETCOM has check valves in the air path and a pressure relief valve. A tightly sealed system may experience a pressure increase with a rise in ambient temperature. The ADH NETCOM will relieve such build-up should it reach 8 psig (552mbar) but it is advised the ADH NETCOM not be used as the only means of overpressure protection.

### DEHYDRATION SYSTEM

The ADH NETCOM is a low pressure automatic air dehydrator. Low pressure air provides personnel and equipment safety along with energy efficiency. Activated alumina is used as the drying agent. Alumina, or aluminum oxide, is an energy efficient desiccant with a long life expectancy.

Air is dehydrated by passing it through a drying canister containing the drying agent. The dried air is delivered to the communications equipment through a connection in the rear panel. The moisture is removed from the drying canisters by heat. The default configuration provides dry air at 0.5 psig (34.5mbar) and is capable of delivering 26 cubic feet of air per hour (12.3 liters per minute).

Two drying canisters provide a continuous supply of dry air. One unit is active while the other is maintained in stand-by or being regenerated. The ADH NETCOM will operate on one of the canisters until the canister is wet enough to trip the dew point sensor. When this occurs, the stand-by drying canister is brought into service and the used unit is regenerated. The drying canister being regenerated is heated internally with a resistance heater until a temperature is attained which will convert all absorbed water into steam. The resulting vapor is purged by pumping ambient air through the drying canister and collecting the water in an evaporator where it is again heated and driven off as water vapor. No drain line or special ventilation is needed with standard units. On ADH NETCOM NEMA units, the purge air and steam is evacuated out of the enclosure either by

using the bronze muffler (supplied), which serves as a moisture diffuser, or through a customer-supplied drain line via the 1/8" NPT discharge fitting, eliminating moisture from inside the weather-tight enclosure.

## PRESSURIZATION

The dual-diaphragm compressor features a brushless motor. It provides a flow rate of 26 scfh (12.3 l/m). The discharge pressure cycles between two limits. These limits are user-configurable in a range between 0.10 psig and 7.50 psig (7mbar - 517mbar) in 0.01 psig (1mbar) increments. Additional information regarding user-configurable settings is provided later in this manual. A safety relief valve operates at 8 psig (552mbar) to provide over-pressure protection.

A solid state pressure transducer senses discharge pressure. The transducer's signal is digitized and processed to control the compressor. The compressor comes on when the pressure falls below the Minimum Pressure and shuts off at the Maximum Pressure.

A High Pressure Alarm occurs if the pressure exceeds the

configured High Pressure Alarm level for more than 30 seconds. The factory default High Pressure Alarm level is 1.5 psig (103.5mbar). A mechanical pressure safety relief valve provides over pressure protection independent of the electronic system. The set point of the safety relief valve is 8 psig (552mbar).

The compressor duty cycle and the discharge pressure are available over the Ethernet or communications ports. Typically, the system should be tight enough to limit the duty cycle to less than 20%. Dehydrator life decreases as duty cycle increases. A Duty Cycle Alarm occurs if the duty cycle exceeds the configured Duty Cycle Alarm level. The factory default Duty Cycle Alarm level is 50%.

## DISPLAYS

Standard display configuration includes two LED indicators on the front panel for POWER and ALARM. Refer to Figure 3. A web interface provides detailed status information display and allows for unit configuration.

### NOTE:

If the temperature in the ADH NETCOM automatic air dehydrator is measured at less than 32°F (0°C), the dehydrator will not turn the compressor on. For NEMA units, an enclosure heater will be energized any time the temperature in the dehydrator is below 40°F (4.4°C).



FIGURE 3. The ADH NETCOM Front Panel.

## COMMUNICATIONS

The ADH NETCOM automatic air dehydrator includes support for both Ethernet network communications and legacy serial communications. The Ethernet capabilities within the ADH NETCOM include support for the web interface, Simple Network Management Protocol (SNMP), User Datagram Protocol (UDP) and Trivial File Transfer Protocol (TFTP). It allows for monitoring and configuration of the dehydrator as well as providing a means for upgrading the dehydrator's software in the field.

The serial capabilities within the ADH NETCOM include legacy support for the Scientific-Atlanta (S-A) protocol used in previous ADH dehydrators. Both RS-422/485 and RS-232 ports are provided for the greatest degree of flexibility.

The ADH NETCOM automatic dehydrator includes three alarm relays for communicating alarm conditions. These are configured at the factory for SUMMARY ALARM, LOW PRESSURE ALARM, and DEW POINT ALARM, but each alarm relay can be user-programmed to any of the alarm conditions tracked by the ADH NETCOM. Each relay has one contact which closes on an alarm condition or loss of power and one contact which opens under the same circumstances. Refer to Table 6 on page 30 of this manual for more information.

### SUPPLY POWER

The ADH NETCOM automatic dehydrator is available in both AC and DC supply power models. AC units have a switching power supply that operates from 100 to 240 VAC, 50/60Hz. DC units have a switching power converter that operates from 20 to 75 VDC with a positive or negative ground system. Neither the AC nor DC units require any customer adjustments to operate within the allowed supply power ranges.

### CANISTER REGENERATION

Drying canister regeneration is controlled by the microprocessor. A thermocouple monitors the temperature of the drying canister. The drying canister

is heated until the desired temperature is reached. The drying canister and its contents are allowed to soak at this temperature for approximately two and one-half hours. The drying canister is then purged by pressurized air into the internal evaporator tray, eliminating the need for a drain line.

If the drying canister fails to reach the desired temperature, it is declared dead and an error is issued. The drying canister is allowed six (6) hours to cool. If it fails to cool to less than 18°F (10°C) above the ambient temperature, the unit is declared dead and an error is issued.

### CONDITIONS FOR REGENERATION

The ADH NETCOM automatic dehydrator has two conditions that will mark a drying canister for regeneration: moisture or time.

During normal operation, regeneration begins when the dew point sensor determines that the discharge air from the canister is "wet." A "wet" condition means a dew point higher than -25°F (-31.7°C), which is still extremely dry air. The amount of time that a drying canister is in service is recorded by the ADH NETCOM. As a precaution, if a drying canister stays in service for 200 hours, the ADH NETCOM will place that canister into regeneration even though sensed moisture has not reached levels that would be considered wet. This ensures that the drying agent is periodically regenerated even in low dew point conditions to extend the life of the drying agent and ensure peak operation of the dehydrator.

When power is initially applied to the unit, operation begins with the use of one drying canister. The discharge air is monitored for moisture for a short time. The first drying canister is taken out of service and the other drying canister is brought into service. If the first drying canister was determined to be wet, it is placed in a regeneration cycle; otherwise, it is placed in stand-by. The second absorption canister is also tested. If the second drying canister is found to be wet, the first drying canister is brought back into use and the second drying

canister is regenerated. The normal regeneration cycle is then entered. If both drying canisters are found to be wet, the drying canister remains in service while the first is regenerated and the dew point alarm is issued.

## SENSORS

The ADH NETCOM automatic air dehydrator has five internal sensors. There are three temperature sensors: the ambient air temperature sensor on the control board, as well as a temperature sensor on the housing of each of the two drying canisters. A fourth sensor, located on the control board, measures the discharge air pressure. The fifth, a dew point sensor, measures the moisture levels in the discharge air.

## CONTROL BOARD

The ADH NETCOM utilizes a single control board which includes the microprocessor, the pressure sensor, and I/O connections for both internal control and external communications. The microprocessor controls all internal dehydrator functions. It acts on data collected from various sensors to control operation of the compressor, absorption canister heaters, and solenoid valves. It monitors system operation and generates status and alarm conditions which are communicated via LED indicators (power and summary alarm), programmable alarm relays, serial I/O interfaces (RS-422/485 and RS-232), and through the communications module. The

communications module is a plug-in board that controls Ethernet networking including SNMP, the web interface, UDP, and TFTP. The control board includes the pressure sensor and the ambient temperature sensor.

## MACHINE PREPARATION AND SET-UP

Before installing the unit as desired for your site, it is first necessary to connect the proper fitting and air line, as well as the power and desired communications cable(s), on the back panel of the machine.

When connecting an equipment or transmission line to the ADH NETCOM automatic air dehydrator, it is first necessary to install the proper fitting onto the port on the back of the unit. Refer to Figure 4. As described on the Inventory page of this manual, two types of brass fittings are supplied with the unit. They are not interchangeable. The first type, Part Number 18198, connects a 1/8" NPT to a 1/4" barbed fitting. The second type of fitting, Part Number 23428, connects a 1/8" NPT to a 3/8" barbed fitting. Though not required, it is recommended to use the second type of fitting, the one with the 3/8" barbed fitting, on runs longer than one hundred (100) feet or about 30 meters or when using the NETCOM as an input to an ASM®-1 Smart Manifold™ Automated Air Distribution Manifold. Directions for the proper installation of both types of fittings are the same.

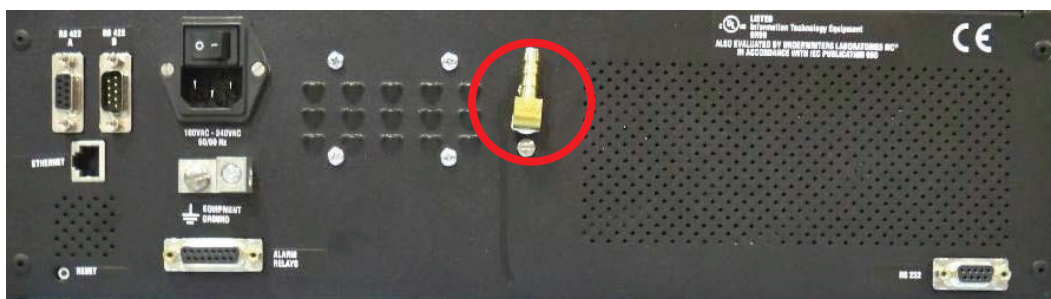

FIGURE 4. ADH NETCOM Rear Panel (with fitting installed).

1. Before installing the fitting onto the back of the dehydrator, first apply some Teflon® thread tape (or compatible thread sealant) around the threads of the fitting you will be using. Refer to Figure 5.

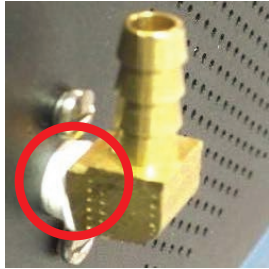

FIGURE 5. Thread Tape on Fitting.

2. Install the fitting into the port on the back of the unit. Finger-tighten the fitting into the port. Using a wrench, fully tighten the fitting onto the port. Carefully rotate the fitting with the wrench at least two more turns to the right or clockwise until fully tightened into the back of the unit.

3. Once the brass fitting has been properly installed onto the ADH NETCOM port, secure the air hose in place on the fitting by pressing the hose tightly onto the fitting.
4. Connect the other end of the hose into the fitting on the waveguide flange or the component to be pressurized with dry air.
5. Prior to connecting the unit power cable, first ground the chassis by connecting the ground lead to the Equipment Ground terminal on the back of the unit. Refer to Figure 6. The three-prong power cable (on AC units) also provides ground protection, but this connection provides redundant ground protection for increased safety.
6. For AC units, after connecting the ground wire, make sure that the unit power switch is in the OFF or "O" position, then plug in the power cable to a surge protecting electrical outlet power strip. Leave the power switch in the OFF position. On DC units, there is no power switch so the unit is functional as soon as the DC power cable is connected. Refer to Figure 7.

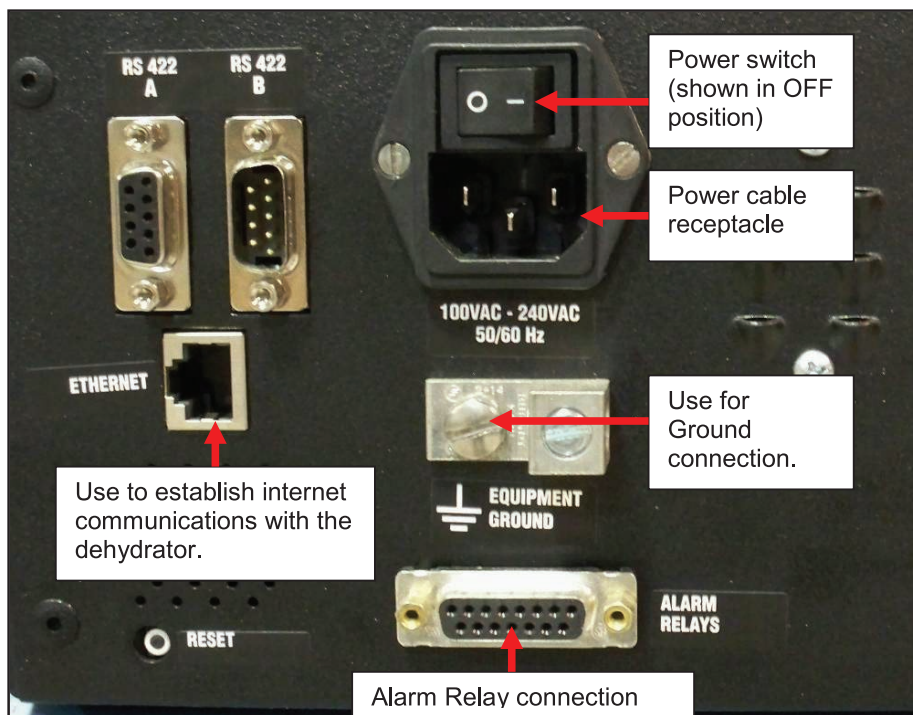

FIGURE 6. ADH NETCOM AC Version Rear Panel Detail.

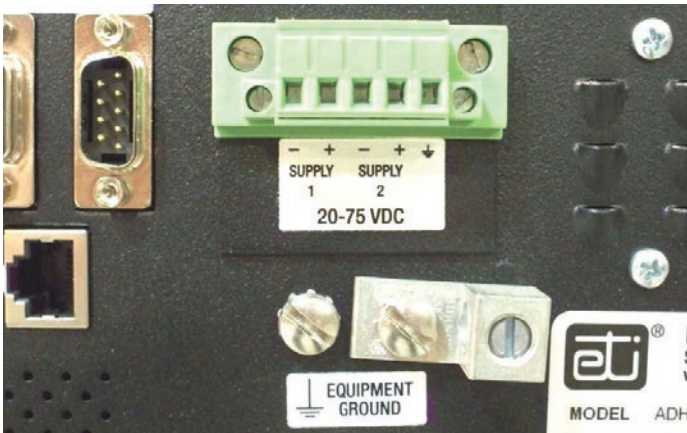

FIGURE 7. ADH NETCOM DC Rear Panel Detail.

### CONFIGURING TWO DEHYDRATORS AS MASTER / SLAVE

In the Configuring The System section in this manual, instructions will be given on configuring two dehydrators to function with each other as master and slave. To be set up as master and slave, it is not necessary for two dehydrators to be physically connected to each other during the configuration process. However, they must be physically connected to each other following configuration in order to be able to function as master and slave to each other.

Although the Ethernet cable is the preferred means of connecting two dehydrators, if you are trying to establish communications between a new dehydrator and an existing one, or to configure a new dehydrator to function with an existing unit, use the RS-422A/B ports between units to make that connection.

If using the Ethernet connection, typically, both units will need to be on the same network. However, if they are not, a cross-over cable must be used between the two dehydrators. In the Serial Port Configuration box, use the pull-down menu to establish that connection, referring to the Help screens that appear when the cursor is placed in that field.

## INSTALLATION

The ADH NETCOM automatic air dehydrator can be rack mounted or mounted to a wall. Refer to Figure 8, as well as the information below.

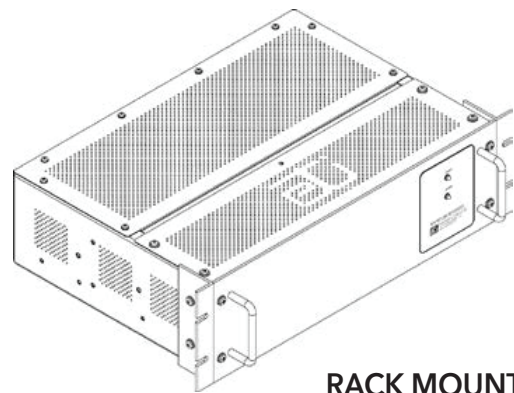

**RACK MOUNT**

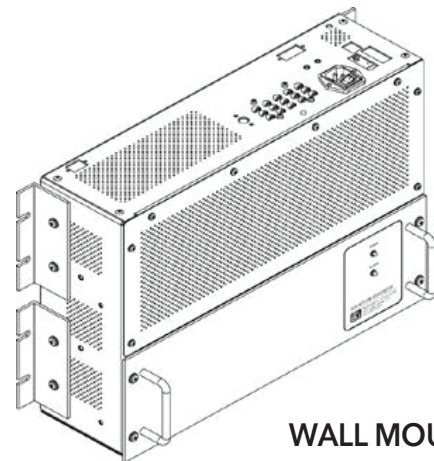

**WALL MOUNT**

FIGURE 8. A standard ADH NETCOM configured for Rack Mount or Wall Mount installation

To configure the dehydrator for wall mount installation, remove the front panel and the portion of the vented cover with the ETI logo, then re-install each where the other had been. Reinstall the front panel so that it will be in the new front position once the dehydrator is oriented for wall mounting. Reinstall the small vented panel so that it will be in the new bottom position. Refer to Figure 9.

Unit comes ready for rack mount installation.

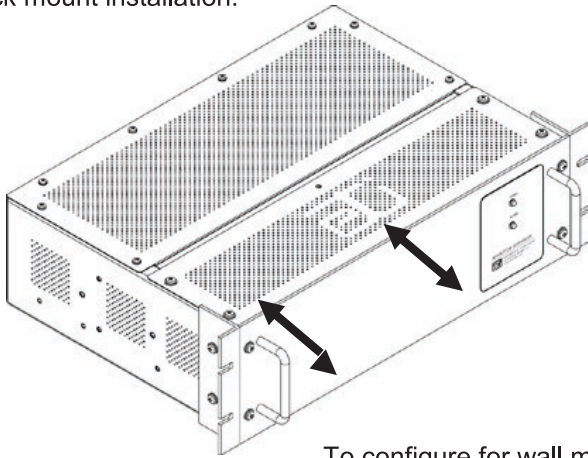

To configure for wall mount installation, remove and switch panels as shown.

FIGURE 9. Switching panels for installation.

### RACK MOUNTING

The ADH NETCOM automatic air dehydrator can be mounted in a standard 19" communications rack at one of four depths utilizing two mounting locations. Mounting depths available are flush, 2", 6", and 8". Refer to Figures 10 through 16. The side panels of the chassis contain tapped holes (#8-32) to facilitate installation. The ADH NETCOM automatic dehydrator should be mounted using chassis slide rails (not supplied) or on support channels mounted on the inside of the relay rack. Because the ADH NETCOM seldom requires operator attention, a location in the lower portion or extreme upper portion of the rack may be considered.

### CAUTION

Before and after rack mounting the ADH NETCOM, ensure that the rack is stable. Mounting of the unit into the rack should be such that a hazardous condition is not created due to uneven mechanical loading. Verify that adequate air flow and power supply capacity is available to the unit. Ensure that the maximum operating temperature of 130°F (55°C) will not be compromised by other components in the rack. Ensure reliable earthing of the ADH NETCOM.

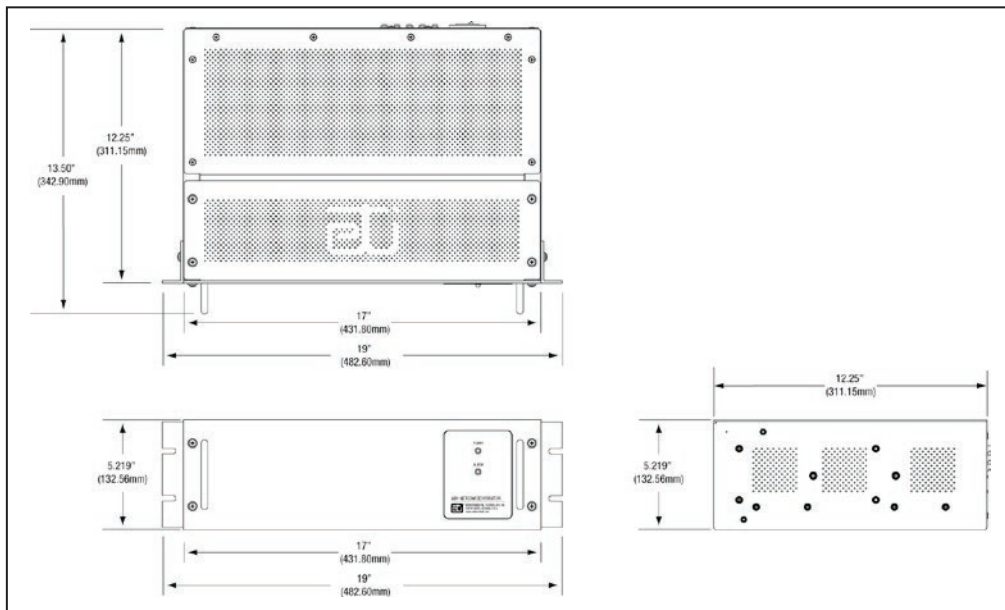

FIGURE 10. ADH NETCOM Rack Mount dimensions.

以上内容仅为本文档的试下载部分，为可阅读页数的一半内容。如要下载或阅读全文，请访问：<https://d.book118.com/488017040013006025>